

Engineering Design.

Experienced engineers

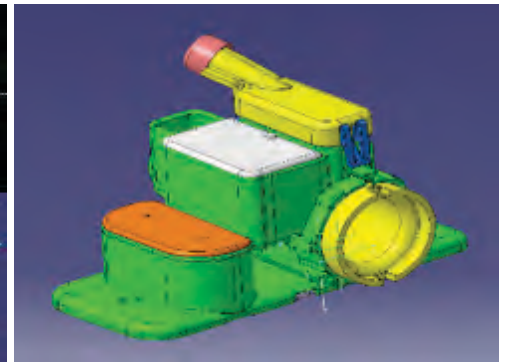
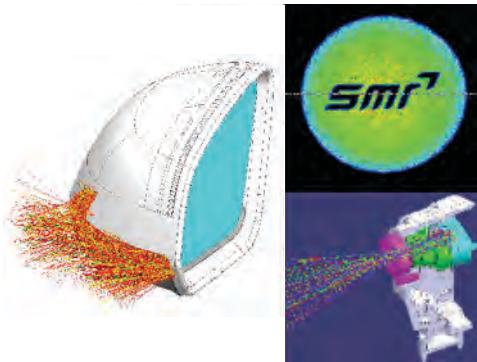
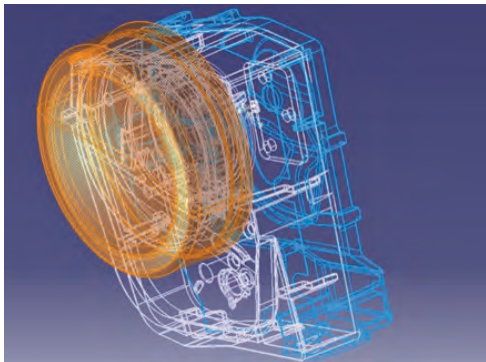
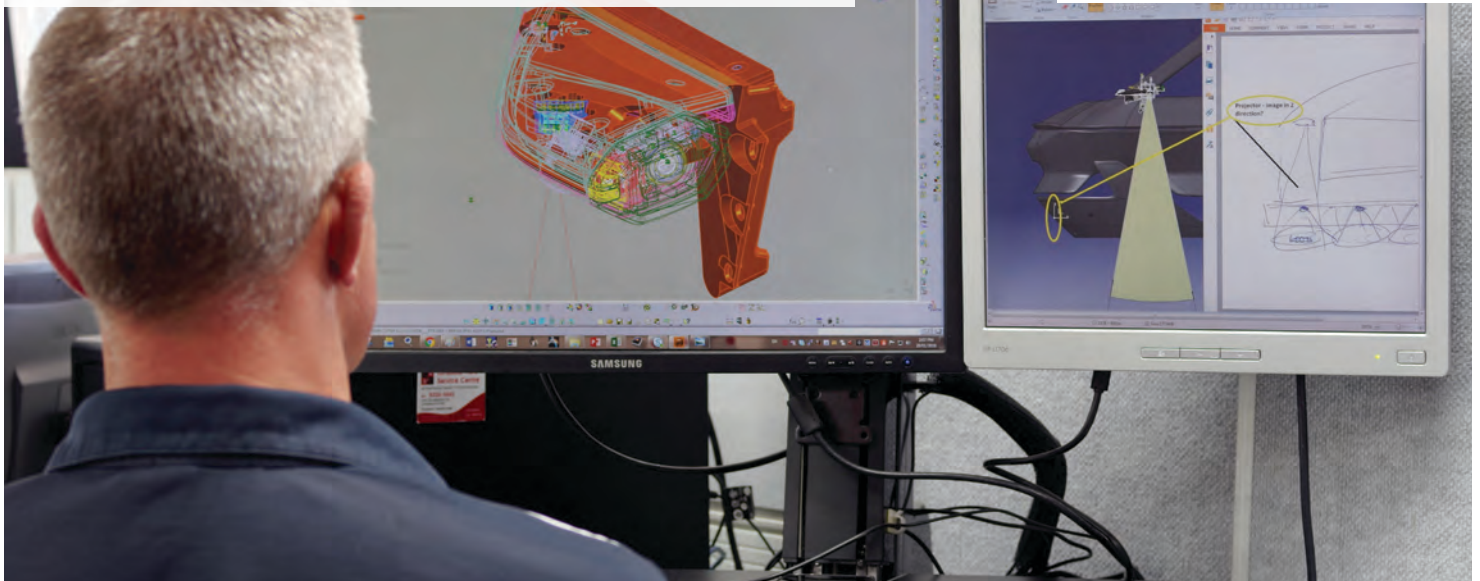

Design and development.

We have a world-class engineering facility, which is based on applied engineering discipline, technical excellence and a cross-functional development team approach.

We take innovative product concepts from Technology Readiness Level 2 or 3 through to clinical trials, device certification and manufacture.

Our experience extends from automotive to medical devices, IoT devices, renewables and more.

We have a dedicated team that evaluates concepts and provides guidance through the entire process.

Our process.

- Concept product design
- Concept prototype ↔ concept validation
- Production product design
- Production product validation
- Production product certification
- Production scale up

We are able to provide ongoing early stage manufacture and assist with expansion beyond the region as well as globalisation.

Computer-aided product design.

- Catia V5: 25+ seats covering surfacing, surface analysis, solid modelling, kinematics, CAE and Smart Team PDM
- Autodesk Inventor
- SDRC Ideas
- Altium PCB design software

CAE/finite element analysis MSC and Hyperworks software suites incorporating:

- Static analysis
- Dynamic analysis
- Linear and non-linear computation
- Structure optimisation
- Kinematic analysis
- Modal analysis
- MOLDFLOW® and MoldEx
- SPEOS optical and lighting analysis
- LucidShape optical design and analysis
- Zemax optical design and analysis
- Thermal/CFD simulation

Project management.

All aspects of the product development life cycle are managed in-house, ensuring complete control of all processes.

From concept to reality, our vertically integrated structure ensures efficient management of each project from agreed quote to quality product, on time and within budget.

Contact us for more information.